

B4260M	Output Power 输出功率:40W~80W	Weight 重量: 320g (Approx.)
---------------	---------------------------	---------------------------

Brushless DC Motor-Typical Application 直流无刷电机-典型应用

With External Auto Grade Driving Controller

含外置车规级驱动控制器 ECU

Specialized for Car Seat Long Slider

专用于汽车座椅高速长滑轨



Model 型号	Voltage(V) 电压		No Load 空载		Rated Load 额定负载				Stall 堵转	
	Operating Range	Rated	Speed (rpm)	Current (A)	Torque (mNm)	Speed (rpm)	Current (A)	Output P. (W)	Torque (mNm)	Current (A)
B4260M-S01	9-16	13.5	10278	1.09	70	7756	6.80	56.86	285.35	24.36

Characteristic: CW & CCW, Signal function available, Locked rotor protection, Stepless speed regulation, Low noise, Low EMI, Long life 3000-30000hrs
特征: 双转向, 信号功能, 锁定保护, 无极调速, 低噪音, 低电磁干扰, 超长寿命 3000-30000 小时

Notice: Data in this typical specification sheet are for other certain customer. Voltage, rated torque, speed, current, power and shaft extension feature & dimension can be changed to meet customer specific requirement.

注意: 上述规格仅针对特定客户, 电压、扭矩、转速、电流、功率、输出轴的特征和尺寸等都可以按照客户的特殊要求进行调整。

Outline Drawing 外形图:

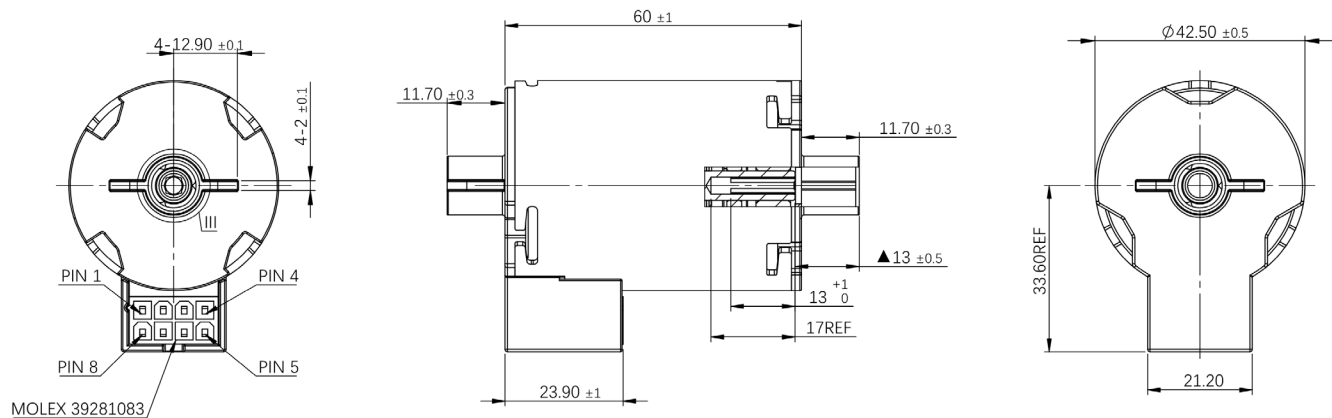

Usable machine screw length 1.5mm max. from motor mounting surface

Unit: Millimeter

Performance Curve 性能曲线:

B4260M-S01

13.5V

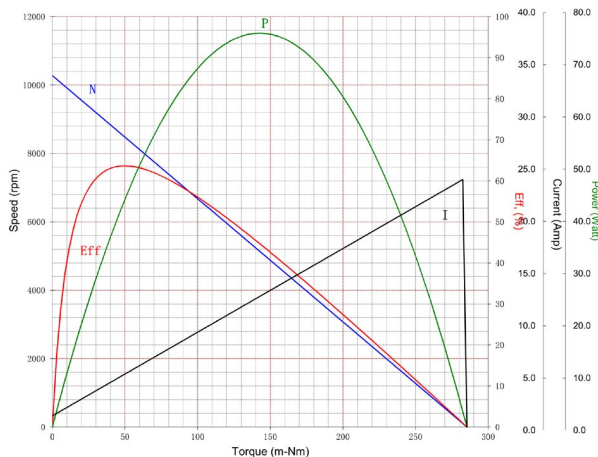

地址: 广东省深圳市宝安区福海新田大道福宁高新产业园 A 栋、F 栋

Address: Building A & F, Funing Hi-Tech Park, Xintian Road, Fuhai, BaoAn District, Shenzhen, Guangdong Province, China

电话 Tel: 86-755-29169191,29169292 传真 Fax: 86-755-29169007 邮箱 Email:sales@hengdrive.com 网址 Http://www.hengdrive.com