

B3630M	Output Power 输出功率: 1W~30W	Weight 重量: 110g (Approx.)
---------------	---------------------------	---------------------------

Brushless DC Motor-Typical Application 无刷直流电机-典型应用
 Home Application: Electric Door, Electric Window, Electric Curtain, Electric Awning
 家用电器: 电动门, 电动窗, 电动窗帘, 电动遮阳棚
 Industry Facility: Transmission Equipment, Gear System, Actuator
 工业设备: 传动机械, 齿轮系统, 致动器
 Electronic Equipment: Electric Valve, Small Switcher, Lighting Adjustor,
 Small Percussion Drill
 电控设备: 电动阀门, 小型转换器, 灯光调节器, 电动扳手
 Business Equipment: Electric Gate, Banking Facility, ATM, Vending Machine
 商业设备: 电动门禁, 银行设施, ATM 机, 售卖机
 Personal Care: Massager 个人护理: 按摩器



Model 型号	Voltage(V) 电压		No Load 空载		Rated Load 额定负载				Stall 堵转	
	Operating Range	Rated	Speed (rpm)	Current (A)	Torque (mNm)	Speed (rpm)	Current (A)	Output P. (W)	Torque (mNm)	Current (A)
B3630M-S01	5.8-12	6	2940	0.39	10.00	2270	0.91	2.38	44.05	2.5
B3630M-S02	8-26	12	5200	0.27	14.72	4260	0.90	6.56	81.30	2.5
B3630M-S03	8-26	24	6970	0.20	19.62	5640	0.76	11.58	102.51	2.5
B3630M-S04	8-26	24	15755	0.39	20.00	13213	1.59	27.67	123.9	3.5

Characteristic: CW & CCW, Signal function available, Locked rotor protection, Stepless speed regulation, Low noise, Low EMI, Long life 10000-50000hrs
特征: 双转向, 信号功能, 锁定保护, 无级调速, 低噪音, 低电磁干扰, 超长寿命 10000-50000 小时

Notice: Data in this typical specification sheet are for other certain customer. Voltage, rated torque, speed, current, power and shaft extension feature & dimension can be changed to meet customer specific requirement.
注意: 上述规格仅针对特定客户, 电压、扭矩、转速、电流、功率、输出轴的特征和尺寸等都可以按照客户的特殊要求进行调整。

Outline Drawing 外形图:

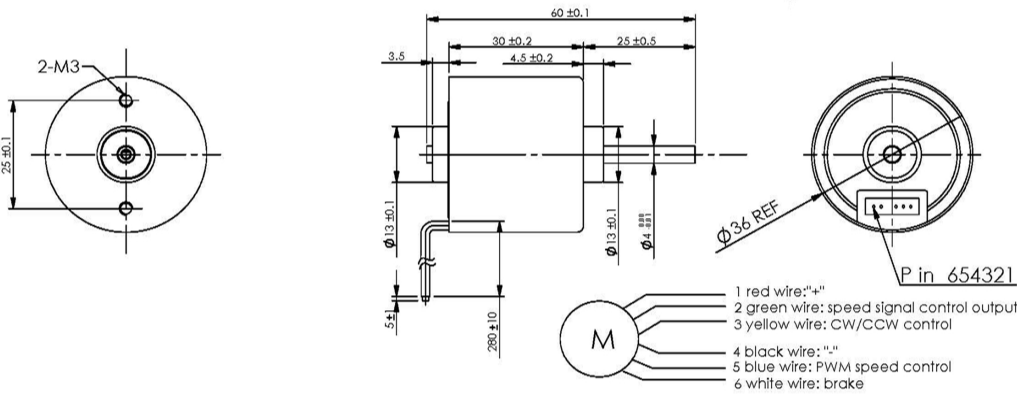

Usable machine screw length 3.0mm max from motor mounting surface

Unit: Millimeter

Performance Curve 性能曲线:

