

<b>B2238M</b>	Output Power 输出功率: 1W~8W	Weight 重量: 54g (Approx.)
---------------	--------------------------	--------------------------

**Brushless DC Motor-Typical Application 直流无刷电机-典型应用**

Home Application: Small Appliance, Electric Curtain, Electric Windows/Door, Small Cross-Flow Fan  
家用电器: 小家电, 电动窗帘, 电动门窗, 小型贯流风机

Medical Apparatus: Medical Pump, Surgery Tools, Medical Stirrer, Centrifugal Machine  
医疗器械: 医疗泵, 手术器械, 搅拌机, 离心机

Industry Facilities: Printing Machine, Binding Machine, Cutting Machine, Electric Valve  
工业设备: 印刷机, 装订机, 裁剪机, 电动阀门

Business Equipment: Cash Register, ATM, TV Set Frame  
商业设备: 点钞机, ATM机, 电视机架

Personal Care: Massager, Vibrator, Malaxation Apparatus, Scrub Apparatus  
个人护理: 按摩器, 震动器, 揉捏器, 磨砂器



Model 型号 (Brushless DC 无刷)	Voltage(V) 电压		No Load 空载		Rated Load 额定负载				Stall 堵转	
	Operating Range	Rated	Speed (rpm)	Current (A)	Torque (mNm)	Speed (rpm)	Current (A)	Output P. (W)	Torque (mNm)	Current (A)
B2238M-S01	5-14	6	4000	0.09	4.61	3075	0.45	1.49	20.0	0.8
B2238M-S02	8-26	12	4480	0.04	3.92	3490	0.19	1.44	17.7	0.85
B2238M-S03	8-26	24	9980	0.08	5.886	8090	0.33	4.98	30.7	0.75

**Characteristic:** CW & CCW, Signal function available, Locked rotor protection, Stepless speed regulation, Low noise, Low EMI, Long life 3000-15000hrs  
**特征:** 双转向, 信号功能, 锁定保护, 无级调速, 低噪音, 低电磁干扰, 超长寿命 3000-15000 小时

**Notice:** Data in this typical specification sheet are for other certain customer. Voltage, rated torque, speed, current, power and shaft extension feature & dimension can be changed to meet customer specific requirement.

**注意:** 上述规格仅针对特定客户, 电压、扭矩、转速、电流、功率、输出轴的特征和尺寸等都可以按照客户的特殊要求进行调整。

**Outline Drawing 外形图:**

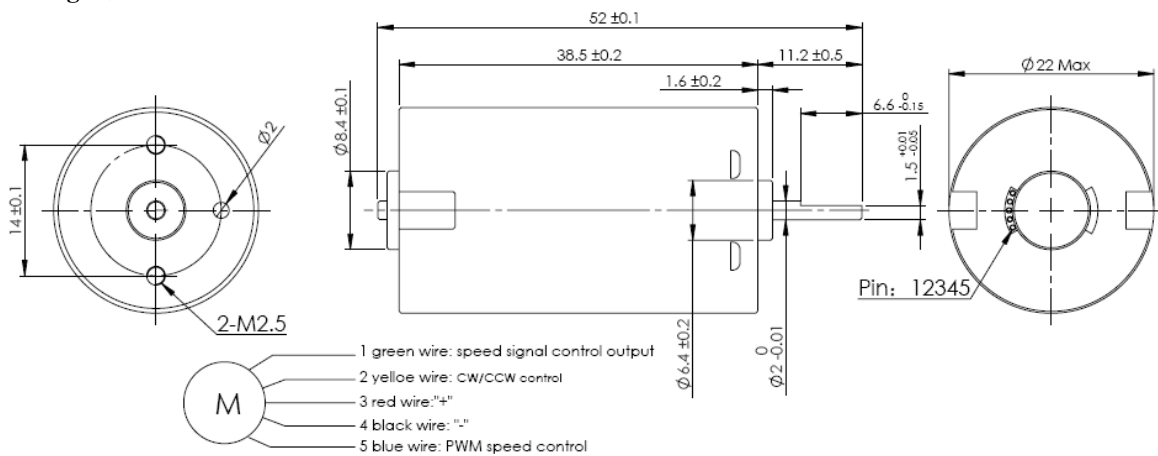

Usable machine screw length 2.5mm max. from motor mounting surface

Unit: Millimeter

**Performance Curve 性能曲线:**

B2238M-S02

12V

B2238M-S03

24V

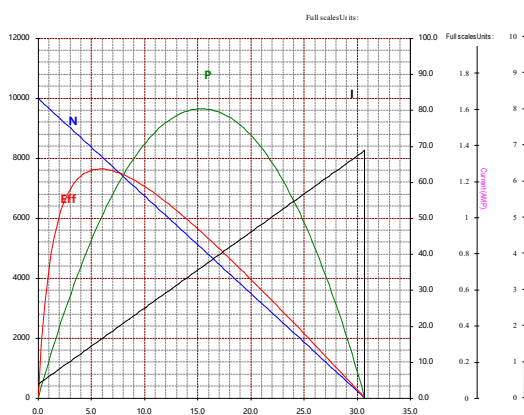
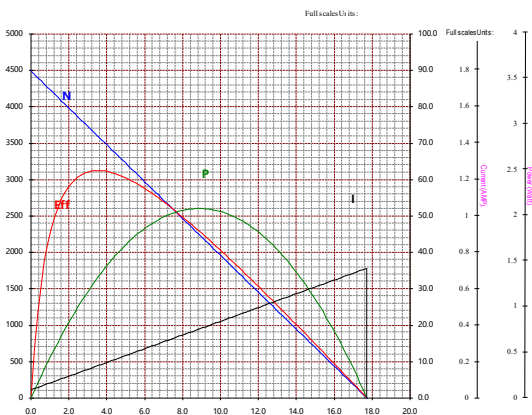

地址: 广东省深圳市宝安区福海新田大道福宁高新产业园 A 栋、F 栋

Address: Building A & F, Funing Hi-Tech Park, Xintian Road, Fuhai, BaoAn District, Shenzhen, Guangdong Province, China

电话 Tel: 86-755-29169191,29169292 传真 Fax: 86-755-29169007 邮箱 Email:sales@hengdrive.com 网址 Http://www.hengdrive.com